

RESU PLUS
Installation Manual
Version 1.0

1. Product Introduction

1.1 Technical Data

- Dimension and Weight

Length	120.5 mm
Width	156.0 mm
Height	216.0 mm
Weight	2.0 kg ↓

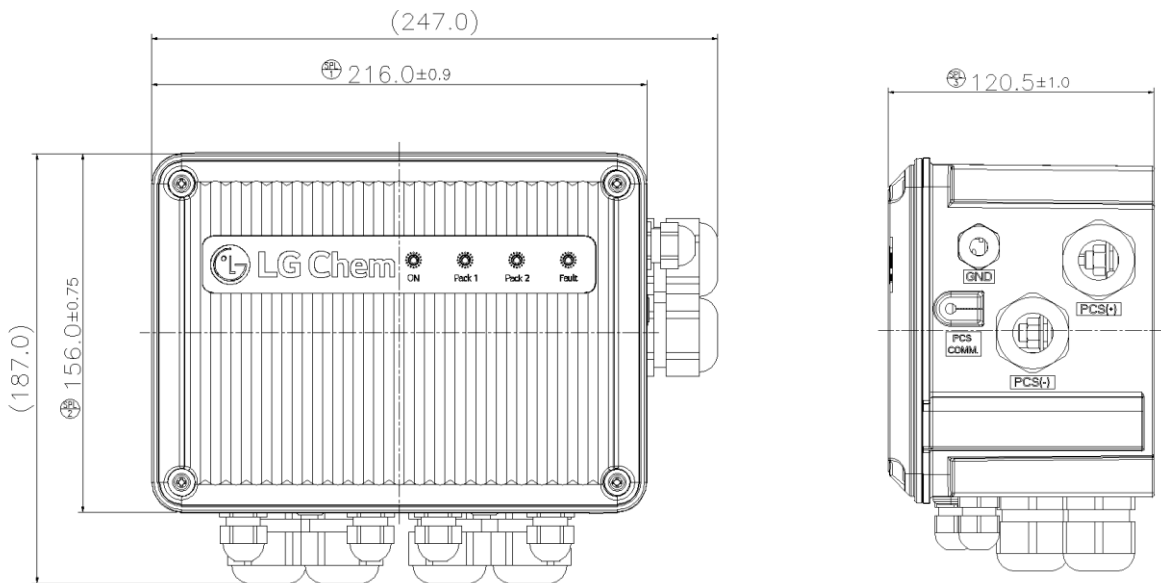

- Charging cable requirements

Conductor cross-sectional area	33 ~ 50mm ²
Cable outer diameter	Max. 18mm
Cable lug hole size	M8
Cable lug width	18mm ↓
Safety	UL recognized

- Environmental requirements

Installed position	Indoor / Outdoor
Installed method	Wall Mount
Operating Temperature	-10 ~ 45°C
Humidity	5 ~ 95%RH

- Available RESU® battery pack models

Model	Energy	Voltage	Current
RESU 3.3	3.3 kWh	42 ~ 58.8V	51 ~ 71.4A
RESU 6.5	6.5kWh	42 ~ 58.8V	71.4 ~ 100A
RESU 10	9.8kWh	42 ~ 58.8V	85 ~ 119A

*** RESU6.4EX Battery Pack can not expand with the Resu Plus**

2. Installation

2.1 Unpacking the package

- Cut the packing tape and open the carton.
- Remove the Cushioning pad.
- Pull out the RESU PLUS and stand it upright. Check if the battery pack is damaged.
- All the other items are contained in a box in one corner of the carton. Take them out and check if any item is missing. See **Package items on page 4.**



2.2 Package item

- These item are included



<Anchor Set 2ea>

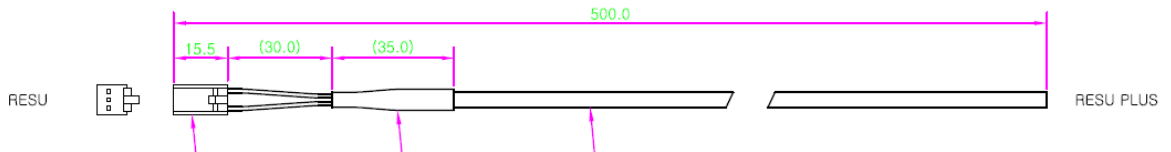

<12V Power Cable 2ea>

- The following table lists the numbers of each item included.

Lager gland for Power cables	6 EA	Assembled in this product
Small gland for other cables	5 EA	Assembled in this product
Grommets for RJ45 cables	3 EA	Assembled in this product
BBMS	1 EA	Assembled in this product
Anchor Bolt	2 EA	Enclosed with this product.
DC Power Cable	2 EA	Enclosed with this product.

- If anything is damaged or missing, contact LG Chem or your distributor.

2.3 Installation materials

- These installation materials shall be prepared by installers.
 - Charging cables with Ring terminals (AWG 2)
 - Network cable
 - Ground wire with Ring terminals (AWG 10)
 - RJ45 plug

2.4 Installation location

- Make sure that the installation location meets the following conditions:
 - The building is designed to withstand earthquakes.
 - The location is far away from the sea, to avoid salt water and humidity.
 - Installed by flat vertical walls and high intensity walls when Anchor Bolts installs.
 - There are no flammable or explosive materials nearby.
 - The normal ambient temperature is between 15 and 30°C.
 - There are no corrosive gases present, including ammonia and acid vapor.

2.5 Tools

- The following tools are required to install the RESU PLUS:



Torque screwdriver



Hex-boxes set



Phillips-screwdriver bit



Drill



Voltmeter

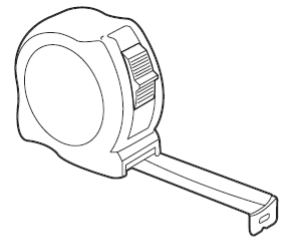

Tape measure



Silicone sealant



Silicone gun

- Use properly insulated tools to prevent accidental electric shock or short circuits.

Use adjustable tools and measuring instruments that are certified for precision and accuracy.

2.6 Safety gear

- Wear the following safety gear when dealing with the battery pack. Installers must meet the relevant requirements of international standards, such as IEC 60364, or the domestic legislation.



Insulated gloves

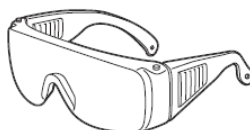

Safety goggles



Safety shoes

2.7 Installation clearance

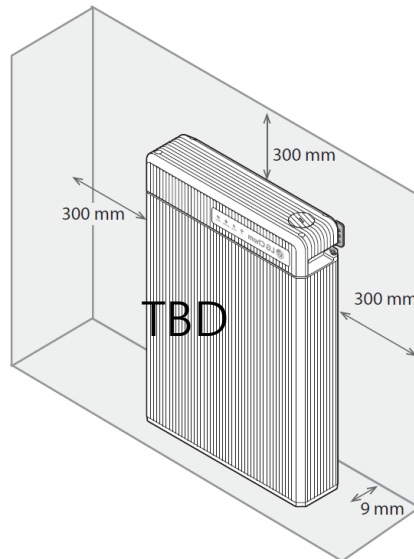

- Make sure to attach between the RESU PLUS and the wall using the Anchor Set. A clearance of at least 300 mm must be left around the RESU PLUS for Insulation to the all directions without a direction of the wall.

2.8 Installing by the wall

- To mount the RESU PLUS to a wall, take the following steps:

1. Remove the top cover. Loosen the four screws at each corner of the top cover, and then pull it upwards.

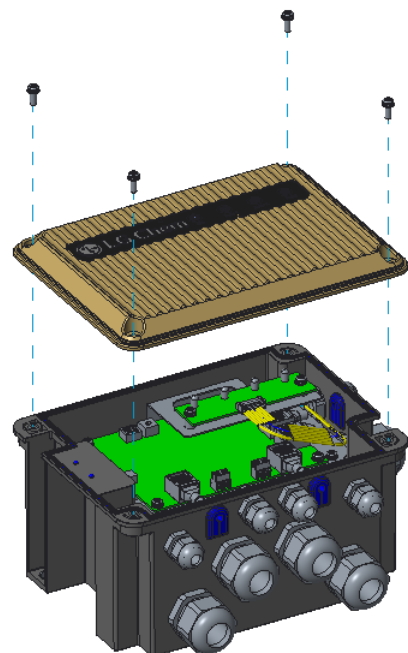

2. Remove the BBMS ass'y. Loosen the four screws at each corner of the BBMS ass'y, and then pull it upwards.

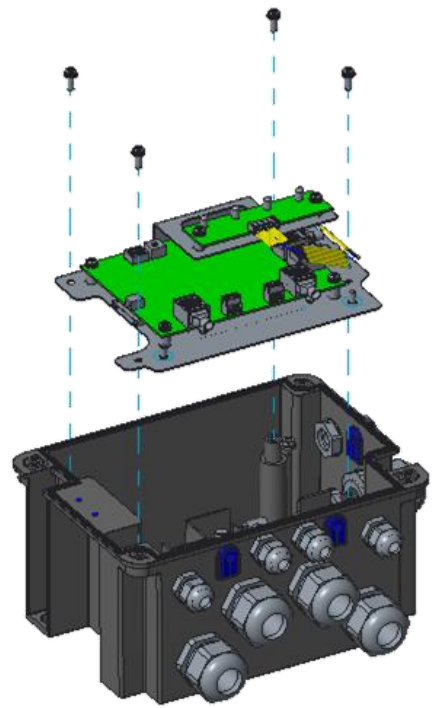

3. Determine where the mounting brackets are to be placed.

4. Drill holes in the wall for M8 (5/16 in) screw anchors. The drilling depth should be at least 50 mm.

5. Drive the screw anchors through the mounting Main HSG into the holes.

6. Tighten the screws to a torque of 5~10 N·m.

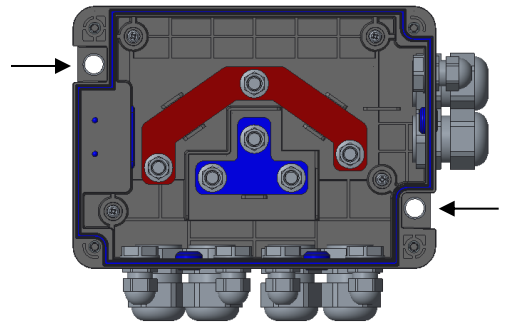

7. Loosen the six M8 Nuts on Main HSG.

8. Charging cables goes through six M25 GLANDs and hooks into the M8 stud screws.

9. Tighten the six M8 Nuts again and then Tighten the six GLANDs as hard as possible.

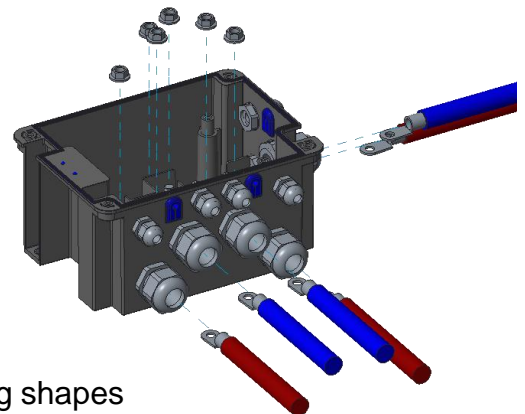

* Warning : When Glands tightens, Check inside sealing shapes



<Good>



<Bad>

10. Assembles BBMS ass`y using the four M4 screws.

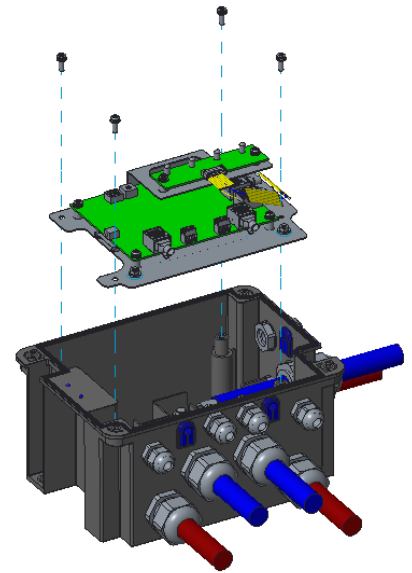

11. Loosen the three M4 Nuts on BBMS ass`y.

12. Ground cables goes through three M12 GLANDs and hooks into the M4 stud bolts.

13. Tighten the three M4 Nuts again and then Tighten the three GLANDs as hard as possible.

14. DC Power cable connects J4 or J9 Terminals in the BBMS through two M12 GLANDs.

* Warning : Be careful the connection polarity.
PLUS(White), Minus(Black)

15. Tighten the three GLANDs as hard as possible.

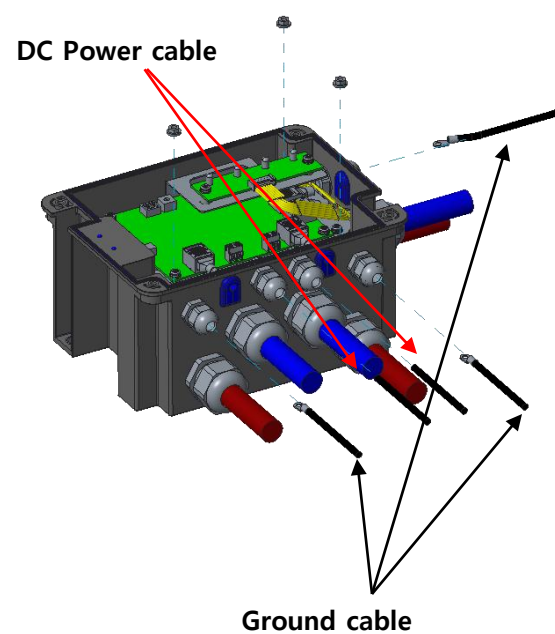

16. Cabling the Network cables.

(Assembles after Network cables puts in the Can cable grommets.)

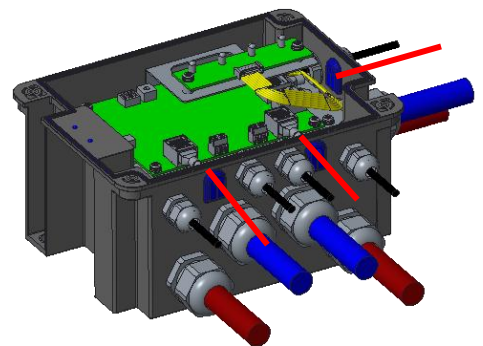

17. The Silicone applies inside the main housing around the Can cable grommet after it assembled.

(for the waterproof)

* Warning : don't have the gap after applying the Silicone.

* Use The Silicone is certified by UL **recognized** or UL94-V2 over.

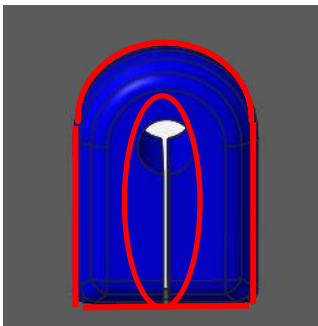

Silicone applies like red line

Silicone applies part

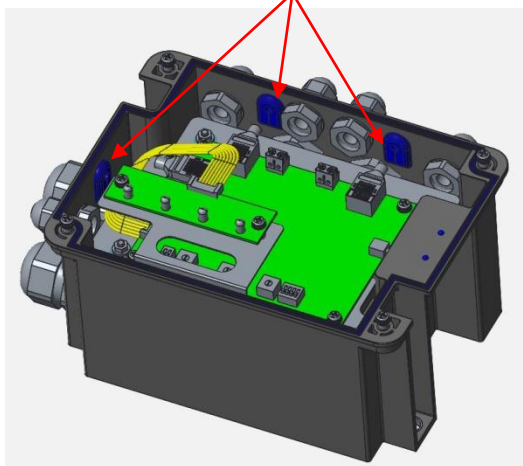

18. Assembles the Top cover using the four M4 screws.

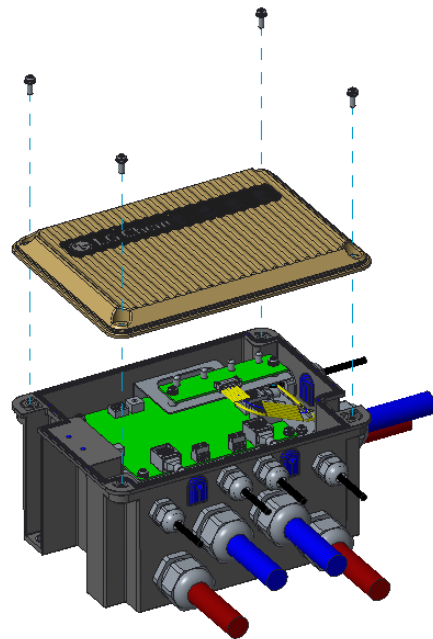

19. Done assembly .

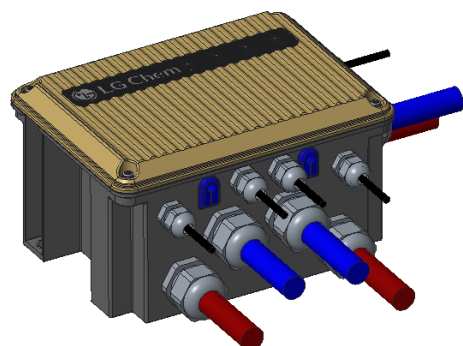

3. Setting for communication interface

3.1 . Inverter Setting

1) Use the SW7 select DIP switch to set what communication interface is used by the inverter.

Any other than those given in the following table is regarded as an invalid setting.

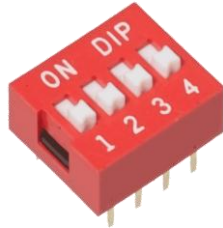

	1	2	3	4
LGC Solo	LOW	LOW	LOW	HIGH
LGC Multi	LOW	LOW	HIGH	LOW
LGC Smart	LOW	LOW	HIGH	HIGH

3.2 Settings for CAN

1) Setting for terminal resistors (SW 1)

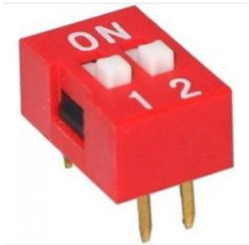

	Type	1	2
1	CAN_Termination resistor not exist	LOW	-
2	CAN_Termination resistor exist	HIGH	-
3	RS485_Termination resistor not exist	-	LOW
4	RS485_Termination resistor exist	-	HIGH

2) Setting for Rotary Switch Pin Map – Sets SW5, SW5, SW6 from Can Comm. PIN Map of the PCS



	SW4	SW5	SW6
Usage	CAN_H	CAN_L	GND

3.3 Connection Kit shipment mode (명칭 수정 필요)

	Parts	No.	Shipment Stat.
1	Rotary switch	SW3	4
2		SW4	5
3		SW5	2
4	Dip switch	SW1	ALL HIGH
5		SW2	LGC Smart

4. Commissioning

4.1 LED indicators

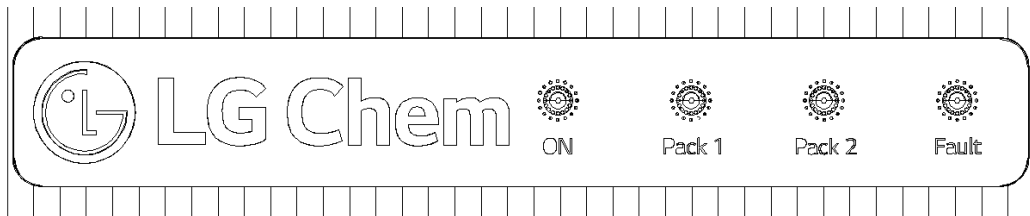

- The LED indicators on the front of the RESU PLUS show its operating state:
 - LED1) ON : Supply the power from Battery and BMS power On
 - LED 2) Online 1(Pack 1) : Done a Battery Online
 - LED 3) Online 2(Pack 2) : Done another a Battery Online
 - LED 4) Warning(Fault) : Check the Battery Fault at least 1ea battery over.
- Cf) Online condition : Contacting the Circuit Breaker and the Main Contactor.

5. Regulatory Approvals

Cooling	Natural convection
Communication interface	CAN 2.0B
Safety	UL1973, CE, RCM
Expected lifetime at 25°C/77°F	More than 10 years
International protection marking	IP55

6. Troubleshooting

6.1 LED Check

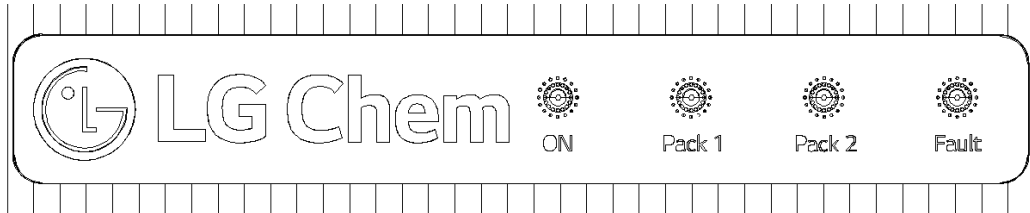

- 1) 'LED 1' OFF
 - Check the 12V power Cable
 - Check the Cable of LED to BMS B/D

- 2) 'LED 4' ON
 - Check the inverter display of error state or check the battery pack state.

6.2 Communication error

- 1) Check the Rotary Switch and Dip Switch setting