

Unidades exteriores

Multisistema

FICHA PRODUCTO



Producto certificado por:



CARACTERÍSTICAS

Modelo	M2O-14N8
Máx. unidades interiores	2
Capacidad frigorífica	4,10 kW
Consumo frío	1,27 kW
Capacidad calorífica	4,39 kW
Consumo calor	1,20 kW
Caudal de aire	2.200 m ³ /h
Presión sonora	57 dB(A)
Alimentación	220-240 V / 1 / 50 Hz
Cableado alimentación (exterior)	(2+T)x2,50 mm ²
Cableado comunicación	(3+T)x2,50 mm ²
Intensidad máx.	12 A
Tuberías frigoríficas	2x Ø1/4" / 2x Ø3/8"
Carga fábrica / Carga adicional	0,90 kg / 0,012 kg
Longitud máx. tuberías	40 m
Longitud máx. por unidad interior	25 m
Diferencia altura entre unidades interior y exterior	15 m
Diferencia altura entre unidades interiores	10 m

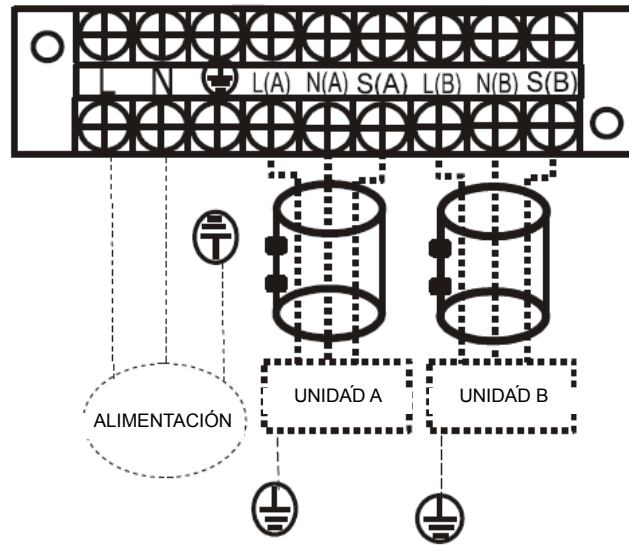

DIMENSIONES Y PESO UNIDAD EXTERIORR

Modelo	M2O-14N8
Ancho	800 mm
Alto	554 mm
Fondo	333 mm
Peso	31,60 kg

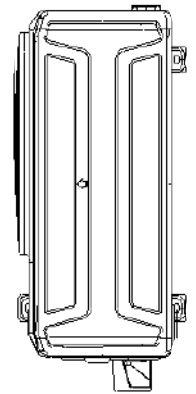
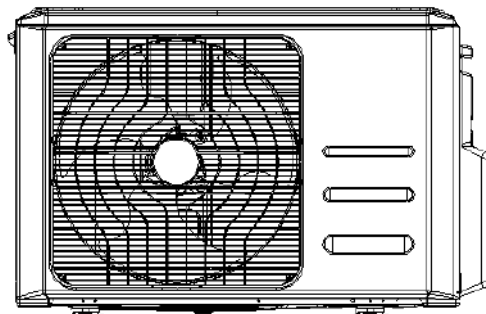

INSTALACIÓN

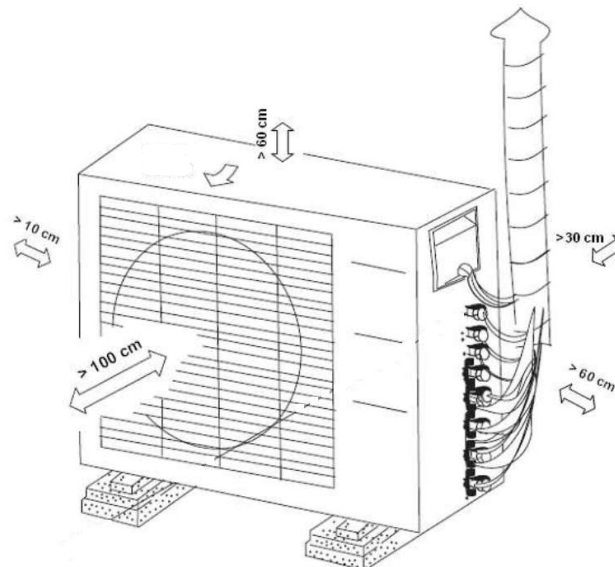

Combinaciones

2x1

M2O-14N8 (R-32)

FRÍO											
Comb. Uni. Int.		Capacidad Nominal (kW)		Capacidad Refrigeración (kW)			Potencia Absorbida (kW)			SEER	Class. Energ.
A	B	A	B	Min.	Nom.	Max.	Min.	Nom.	Max.		
7	—	2.0	—	1.2	2.0	2.9	0.3	0.6	0.8	—	—
9	—	2.5	—	1.2	2.5	3.2	0.3	0.8	1.0	—	—
12	—	3.5	—	1.2	3.5	3.9	0.3	1.1	1.3	—	—
18	—	4.1	—	1.4	4.1	4.9	0.4	1.3	1.6	—	—
7	7	2.1	2.1	1.8	4.1	4.9	0.4	1.3	1.6	6.8	A++
7	9	1.8	2.3	1.8	4.1	4.9	0.4	1.3	1.6	6.8	A++
7	12	1.5	2.6	1.8	4.1	4.9	0.4	1.3	1.6	6.8	A++
9	9	2.1	2.1	1.8	4.1	4.9	0.4	1.3	1.6	6.8	A++
9	12	1.8	2.3	1.8	4.1	4.9	0.4	1.3	1.6	6.8	A++

CALOR											
Comb. Uni. Int.		Capacidad Nominal (kW)		Capacidad Calorífica (kW)			Potencia Absorbida (kW)			SCOP	Class. Energ.
A	B	A	B	Min.	Nom.	Max.	Min.	Nom.	Max.		
7	—	2.5	—	1.3	2.5	2.8	0.3	0.7	0.8	—	—
9	—	2.9	—	1.3	2.9	3.4	0.3	0.8	1.0	—	—
12	—	3.8	—	1.3	3.8	4.3	0.3	1.0	1.3	—	—
18	—	4.4	—	1.5	4.4	5.2	0.4	1.2	1.5	—	—
7	7	2.2	2.2	1.9	4.4	5.3	0.4	1.2	1.5	4.0	A+
7	9	1.9	2.5	1.9	4.4	5.3	0.4	1.2	1.5	4.0	A+
7	12	1.6	2.8	1.9	4.4	5.3	0.4	1.2	1.5	4.0	A+
9	9	2.2	2.2	1.9	4.4	5.3	0.4	1.2	1.5	4.0	A+
9	12	1.9	2.5	1.9	4.4	5.3	0.4	1.2	1.5	4.0	A+

M2O-18N8 (R-32)

FRÍO											
Comb. Uni. Int.		Capacidad Nominal (kW)		Capacidad Refrigeración (kW)			Potencia Absorbida (kW)			SEER	Class. Energ.
A	B	A	B	Min.	Nom.	Max.	Min.	Nom.	Max.		
7	—	2.0	—	1.4	2.0	2.9	0.4	0.6	0.7	—	—
9	—	2.5	—	1.4	2.5	3.2	0.4	0.7	0.9	—	—
12	—	3.5	—	1.4	3.5	3.9	0.4	1.1	1.3	—	—
18	—	5.0	—	1.6	5.0	5.5	0.5	1.5	1.9	—	—
7	7	2.1	2.1	2.1	4.2	5.6	0.5	1.2	2.0	6.1	A++
7	9	2.1	2.6	2.1	4.7	5.8	0.5	1.5	2.0	6.1	A++
7	12	1.9	3.3	2.1	5.2	6.4	0.5	1.6	2.0	6.1	A++
9	9	2.7	2.7	2.1	5.3	6.4	0.5	1.6	2.0	6.1	A++
9	12	2.3	3.0	2.1	5.3	6.4	0.5	1.6	2.0	6.1	A++
12	12	2.7	2.7	2.1	5.3	6.4	0.5	1.6	2.0	6.1	A++

CALOR											
Comb. Uni. Int.		Capacidad Nominal (kW)		Capacidad Calorífica (kW)			Potencia Absorbida (kW)			SCOP	Class. Energ.
A	B	A	B	Min.	Nom.	Max.	Min.	Nom.	Max.		
7	—	2.5	—	1.6	2.5	3.0	0.3	0.7	0.8	—	—
9	—	3.0	—	1.6	3.0	3.6	0.3	0.8	1.0	—	—
12	—	3.8	—	1.6	3.8	4.6	0.3	1.0	1.2	—	—
18	—	5.2	—	1.7	5.2	5.8	0.4	1.4	1.9	—	—
7	7	2.5	2.5	2.2	5.0	6.0	0.5	1.3	1.9	4.0	A+
7	9	2.3	3.0	2.2	5.3	6.1	0.5	1.4	1.9	4.0	A+
7	12	2.0	3.5	2.2	5.5	6.4	0.5	1.5	1.9	4.0	A+
9	9	2.8	2.8	2.2	5.6	6.7	0.5	1.5	1.9	4.0	A+
9	12	2.4	3.2	2.2	5.6	6.7	0.5	1.5	1.9	4.0	A+
12	12	2.8	2.8	2.2	5.6	7.0	0.5	1.5	1.9	4.0	A+

3x1

M3O-21N8 (R-32)

FRÍO													
Comb. Uni. Int.			Capacidad Nominal (kW)			Capacidad Refrigeración (kW)			Potencia Absorbida (kW)			SEER	Class. Energ.
A	B	C	A	B	C	Min.	Nom.	Max.	Min.	Nom.	Max.		
7	—	—	2.0	—	—	1.4	2.0	2.9	0.4	0.6	0.8	—	—
9	—	—	2.5	—	—	1.4	2.5	3.2	0.4	0.8	1.0	—	—
12	—	—	3.5	—	—	1.4	3.5	3.9	0.4	1.1	1.3	—	—
18	—	—	5.0	—	—	1.6	5.0	5.5	0.5	1.5	1.8	—	—
7	7	—	2.1	2.1	—	2.0	4.2	5.5	0.6	1.3	1.9	6.1	A++
7	9	—	2.1	2.6	—	2.0	4.7	5.8	0.6	1.5	2.0	6.1	A++
7	12	—	2.0	3.3	—	2.0	5.3	6.1	0.6	1.6	2.1	6.1	A++
7	18	—	1.8	4.5	—	2.0	6.3	6.8	0.6	2.0	2.2	6.1	A++
9	9	—	2.7	2.7	—	2.0	5.3	6.4	0.6	1.6	2.1	6.1	A++
9	12	—	2.6	3.4	—	2.0	6.0	6.6	0.6	1.9	2.1	6.1	A++
9	18	—	2.1	4.2	—	2.0	6.3	6.8	0.6	1.9	2.2	6.1	A++
12	12	—	3.1	3.1	—	2.0	6.2	6.8	0.6	1.9	2.2	6.1	A++
7	7	7	2.0	2.0	2.0	2.4	6.1	7.2	0.7	1.9	2.4	6.5	A++
7	7	9	1.9	1.9	2.5	2.4	6.3	7.3	0.7	2.0	2.4	6.5	A++
7	7	12	1.7	1.7	2.9	2.4	6.3	7.3	0.7	1.9	2.4	6.5	A++
7	9	9	1.8	1.8	2.3	2.4	6.3	7.3	0.7	1.9	2.4	6.5	A++
9	9	9	2.1	2.1	2.1	2.4	6.3	7.3	0.7	1.9	2.4	6.5	A++

CALOR													
Comb. Uni. Int.			Capacidad Nominal (kW)			Capacidad Calorífica (kW)			Potencia Absorbida (kW)			SCOP	Class. Energ.
A	B	C	A	B	C	Min.	Nom.	Max.	Min.	Nom.	Max.		
7	—	—	2.5	—	—	1.4	2.5	3.0	0.4	0.7	0.8	—	—
9	—	—	3.0	—	—	1.4	3.0	3.6	0.4	0.8	1.0	—	—
12	—	—	3.8	—	—	1.4	3.8	4.6	0.4	1.0	1.2	—	—
18	—	—	5.2	—	—	1.6	5.2	6.0	0.5	1.4	2.0	—	—
7	7	—	2.5	2.5	—	2.2	5.0	5.9	0.5	1.3	1.8	3.8	A
7	9	—	2.5	3.2	—	2.2	5.6	6.3	0.5	1.5	1.9	3.8	A
7	12	—	2.2	3.7	—	2.2	5.9	6.6	0.5	1.6	1.9	3.8	A
7	18	—	1.8	4.7	—	2.2	6.5	7.4	0.5	1.8	2.0	4.0	A+
9	9	—	3.0	3.0	—	2.2	5.9	6.9	0.5	1.6	1.9	3.8	A
9	12	—	2.7	3.6	—	2.2	6.3	7.1	0.5	1.7	2.0	4.0	A+
9	18	—	2.2	4.4	—	2.2	6.6	7.4	0.5	1.8	2.0	4.0	A+
12	12	—	3.2	3.2	—	2.2	6.3	7.4	0.5	1.7	2.0	4.0	A+
7	7	7	2.2	2.2	2.2	2.3	6.6	7.8	0.6	1.8	2.2	4.0	A+
7	7	9	2.0	2.0	2.6	2.3	6.7	7.8	0.6	1.8	2.2	4.0	A+
7	7	12	1.8	1.8	3.1	2.3	6.7	7.9	0.6	1.8	2.2	4.0	A+
7	9	9	1.9	1.9	2.4	2.3	6.7	7.9	0.6	1.8	2.2	4.0	A+
9	9	9	2.2	2.2	2.2	2.3	6.7	7.9	0.6	1.8	2.2	4.0	A+

M3O-27N8 (R-32)

FRÍO													
Comb. Uni. Int.			Capacidad Nominal (kW)			Capacidad Refrigeración (kW)			Potencia Absorbida (kW)			SEER	Class. Energ.
A	B	C	A	B	C	Min.	Nom.	Max.	Min.	Nom.	Max.		
7	—	—	2.0	—	—	1.6	2.0	2.9	0.4	0.6	0.8	—	—
9	—	—	2.5	—	—	1.6	2.5	3.2	0.4	0.8	1.0	—	—
12	—	—	3.5	—	—	1.6	3.5	3.9	0.4	1.1	1.3	—	—
18	—	—	5.0	—	—	1.8	5.0	5.5	0.5	1.5	1.8	—	—
7	7	—	2.1	2.1	—	2.2	4.2	6.3	0.6	1.3	2.1	5.6	A+
7	9	—	2.1	2.6	—	2.2	4.7	6.7	0.6	1.5	2.2	5.6	A+
7	12	—	2.0	3.3	—	2.2	5.3	7.1	0.6	1.6	2.4	5.6	A+
7	18	—	1.8	4.7	—	2.2	6.5	7.9	0.6	2.0	2.7	5.6	A+
9	9	—	2.7	2.7	—	2.2	5.3	7.1	0.6	1.6	2.4	5.6	A+
9	12	—	2.6	3.4	—	2.2	6.0	7.5	0.6	1.9	2.6	5.6	A+
9	18	—	2.3	4.5	—	2.2	6.8	7.9	0.6	2.1	2.7	5.6	A+
12	12	—	3.2	3.2	—	2.2	6.3	7.7	0.6	1.9	2.6	5.6	A+
12	18	—	2.7	4.1	—	2.2	6.8	7.9	0.6	2.1	2.7	5.6	A+
7	7	7	2.4	2.4	2.4	2.8	7.3	8.7	0.8	2.3	2.9	6.1	A++
7	7	9	2.3	2.3	2.9	2.8	7.4	8.7	0.8	2.3	2.9	6.1	A++
7	7	12	2.1	2.1	3.6	2.8	7.9	8.7	0.8	2.4	2.9	6.1	A++
7	9	9	2.1	2.7	2.7	2.8	7.6	8.7	0.8	2.4	2.9	6.1	A++
7	9	12	2.0	2.5	3.4	2.8	7.9	8.7	0.8	2.4	2.9	6.1	A++
7	12	12	1.8	3.1	3.1	2.8	7.9	8.7	0.8	2.4	2.9	6.1	A++
9	9	9	2.6	2.6	2.6	2.8	7.9	8.7	0.8	2.4	2.9	6.1	A++
9	9	12	2.4	2.4	3.2	2.8	7.9	8.7	0.8	2.4	2.9	6.1	A++
9	12	12	2.2	2.2	2.9	2.8	7.9	8.7	0.8	2.4	2.9	6.1	A++
12	12	12	2.6	2.6	2.6	2.8	7.9	8.7	0.8	2.4	2.9	6.1	A++

CALOR													
Comb. Uni. Int.			Capacidad Nominal (kW)			Capacidad Calorífica (kW)			Potencia Absorbida (kW)			SCOP	Class. Energ.
A	B	C	A	B	C	Min.	Nom.	Max.	Min.	Nom.	Max.		
7	—	—	2.5	—	—	1.6	2.5	2.9	0.4	0.7	0.8	—	—
9	—	—	3.0	—	—	1.6	3.0	3.2	0.4	0.8	1.0	—	—
12	—	—	3.8	—	—	1.6	3.8	3.9	0.4	1.0	1.2	—	—
18	—	—	5.2	—	—	1.9	5.2	7.2	0.5	1.4	1.6	—	—
7	7	—	2.5	2.5									